

Recommended composition and installation of injectors with 4,6 and 8 cylinder engines depending on the power and engine type.

1. For 4 cylinder engine not exceeding 150 HP we recommend (depending on its construction possibilities, available space etc.) the following options:

1.1. Injection rail:

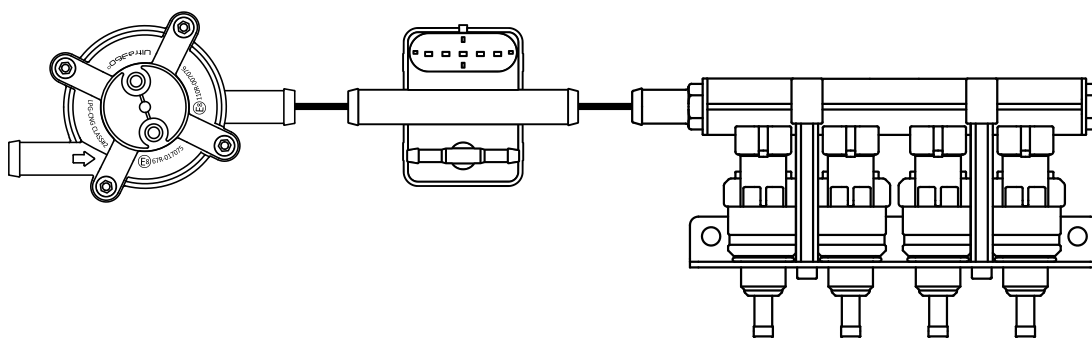

Article	Code
Filter gf1212	C052-10-10-00-00
injection rail br124p	C032-04-04-00-00

1.2. Single injectors with connectors + gas distributor "4":

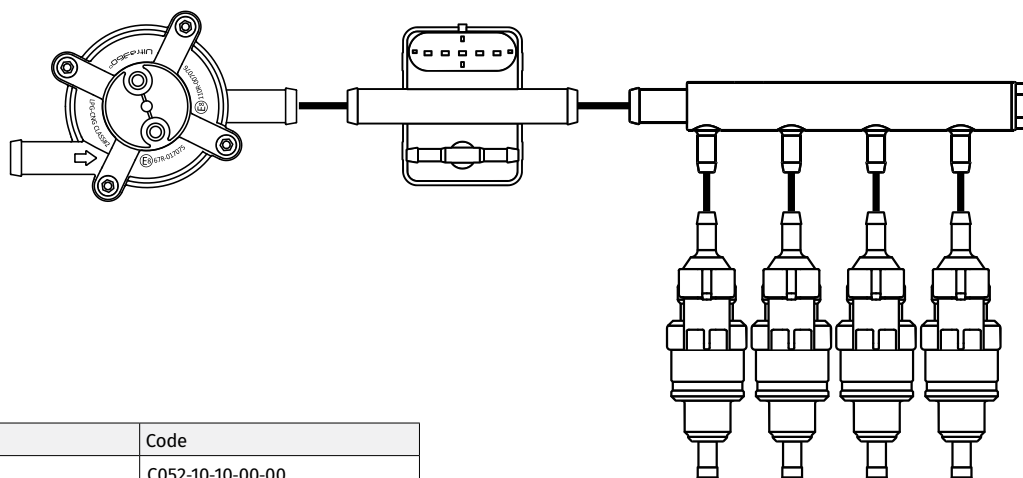

Article	Code
Filter gf1212	C052-10-10-00-00
gas distributor	C028-04-00-00-00
4x injector	C027-15-19-60-00

1.3. Single injectors + t-type adapters and l-type adapter at the end of injector line.

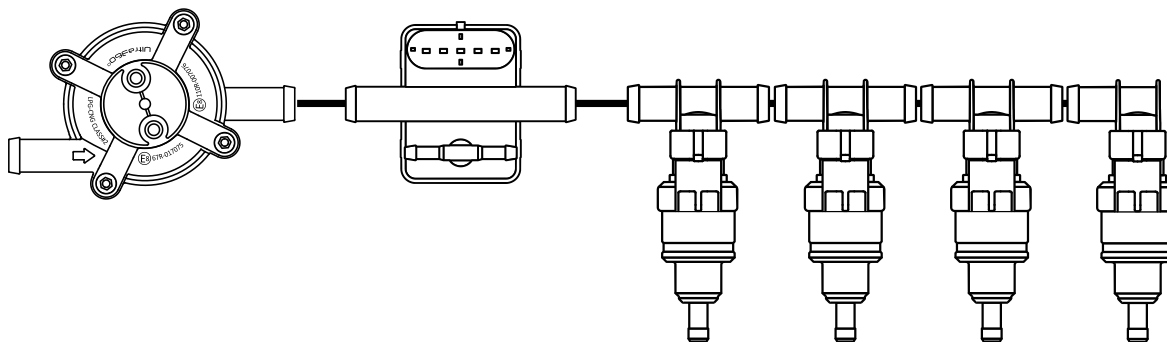

Article	Code
Filter gf1212	C052-10-10-00-00
4x injector	C027-15-19-60-00
3x T-type adapter BD221P	C056-00-00-01-99
L-type adapter BD121P	C056-00-00-02-99

1.4. With the engine power exceeding 150 HP we recommend to use the filter with two outputs to supply the injectors on both sides, e.g.:

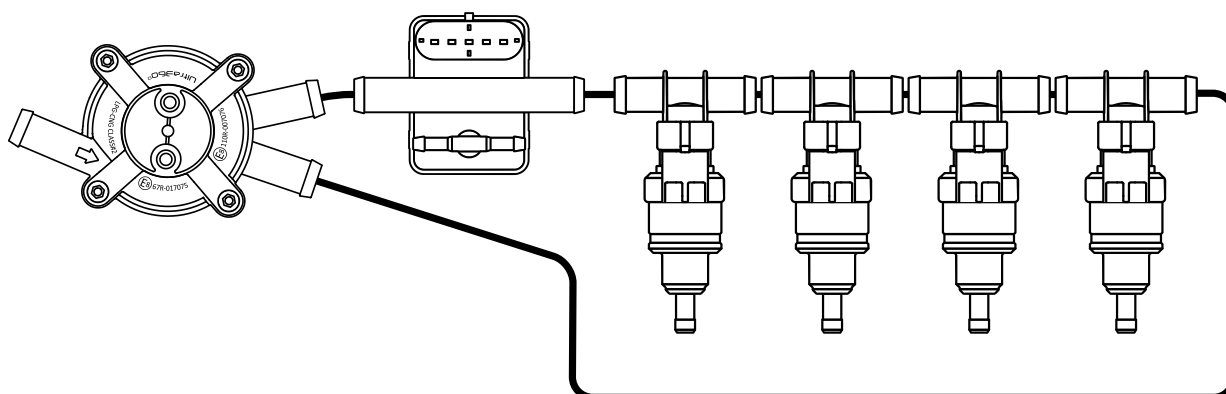

Article	Code
Filter GF1222	C052-12-22-01-00
4x injector	C027-15-19-60-00
4x T- type adapter BD221P	C056-00-00-01-99

Above 180-200 HP we recommend to use the reducer with outlet port fi **16mm (TURBOT 1200-1500)** filter **GF1622** and injectors with increased flow rate - **Barracuda 130nL**. In addition, the reducer supplying tube in the liquid phase should have an increased diameter (equivalent to a copper cable with a diameter of 8mm), and an Extra type multivalve in the gas tank.

2. V-type or inline 6 cylinder engine with its power not exceeding 180 HP:

2.1. Two injection rails with 3 injectors:

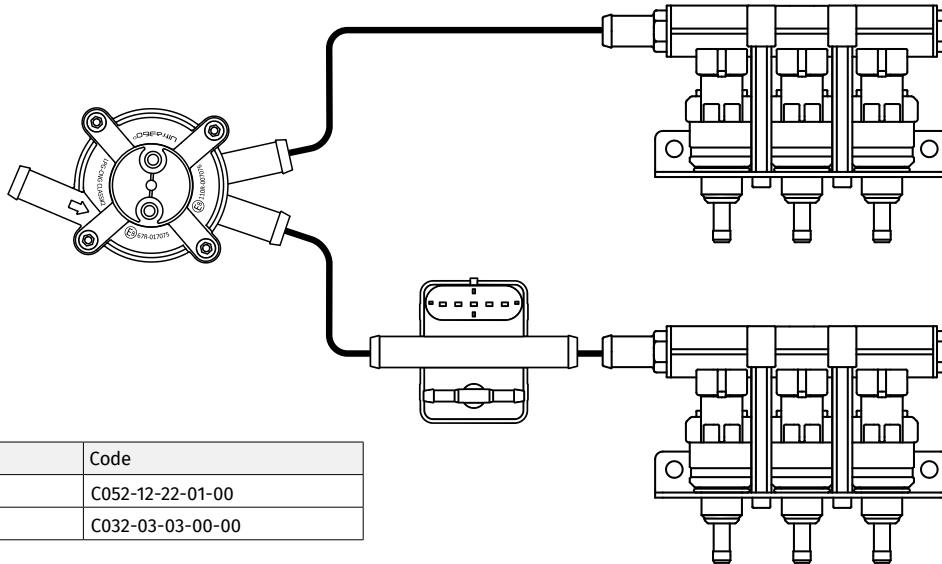

Article	Code
Filter GF1222	C052-12-22-01-00
2xRAIL BR 123P	C032-03-03-00-00

2.2. Single injectors with connectors + gas distributor "3":

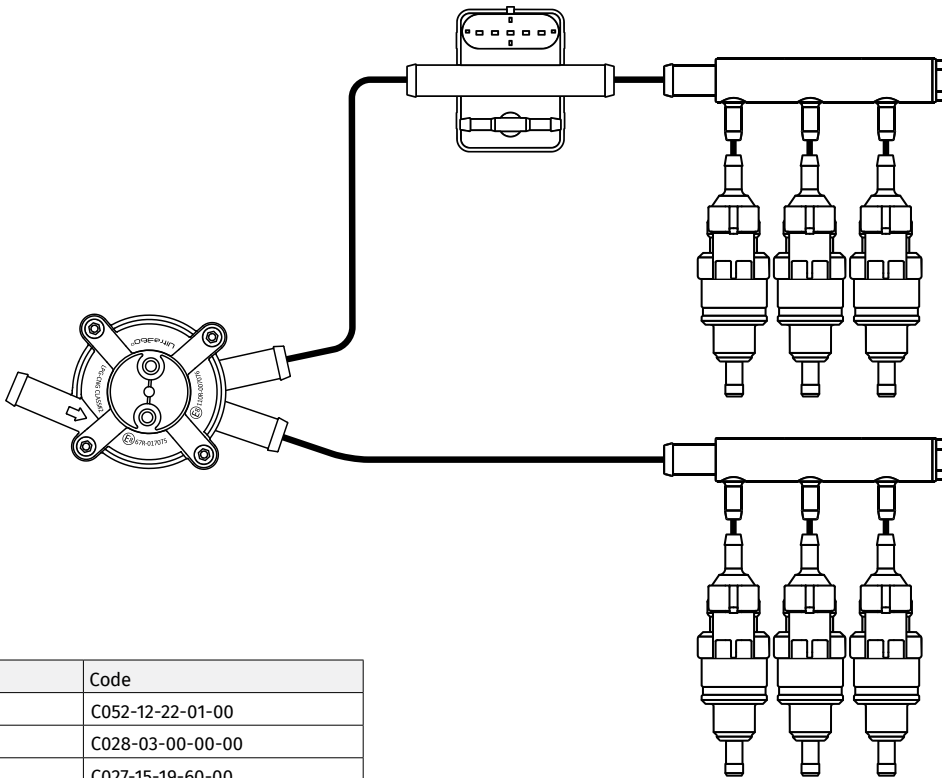

Article	Code
filter GF1222	C052-12-22-01-00
2x Gas distributor	C028-03-00-00-00
6x injector	C027-15-19-60-00

2.3. Single injectors + T-type adapters and L-type adapter at the end of each injector line:

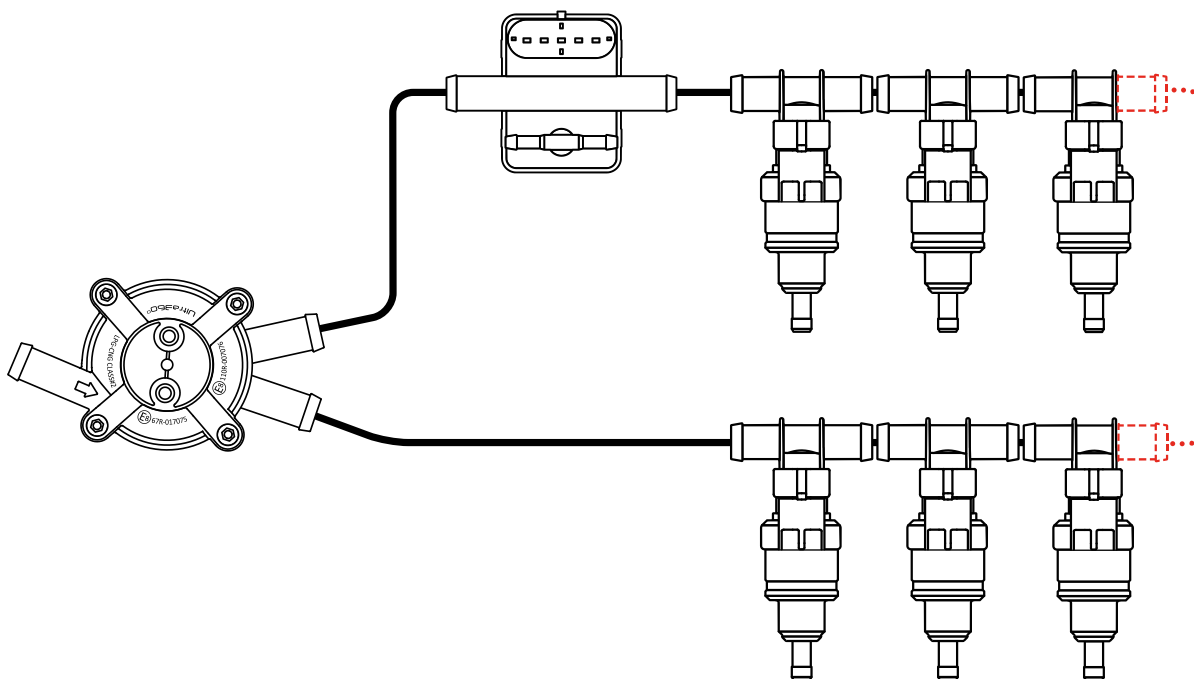

Article	Code
Filter GF1222	C052-12-22-01-00
6 x injector	C027-15-19-60-00
4 x T-type adapter BD221P	C056-00-00-01-99
2 x L-type adapter BD121P	C056-00-00-02-99

With the V-type and inline engines we recommend to join the ends of supply rails (so called compensation). With the engines above 180-200HP we recommend to use the reducer with outlet port fi 16mm (TURBOT 1200-1500) filter GF1622. Above 250HP we recommend to use two reducers, two filters GF1212 or filter 4x12mm and injectors with increased flow rate - Barracuda 130nl.

Article	Code
Filter GF1222	C052-12-22-01-00
6 x injector	C027-15-19-60-00
6 x T-type adapter BD221P	C056-00-00-01-99

- 3. All the 8 cylinder engines are practically V-type engines with their power exceeding 200 HP therefore we recommend to use the reducer with outlet port fi 16mm (TURBOT 1200-1500) or two reducers, if the power exceeds 250HP. It is also necessary to use so called compensation. Options:**

3.1. Two injection rails with 4 injectors:

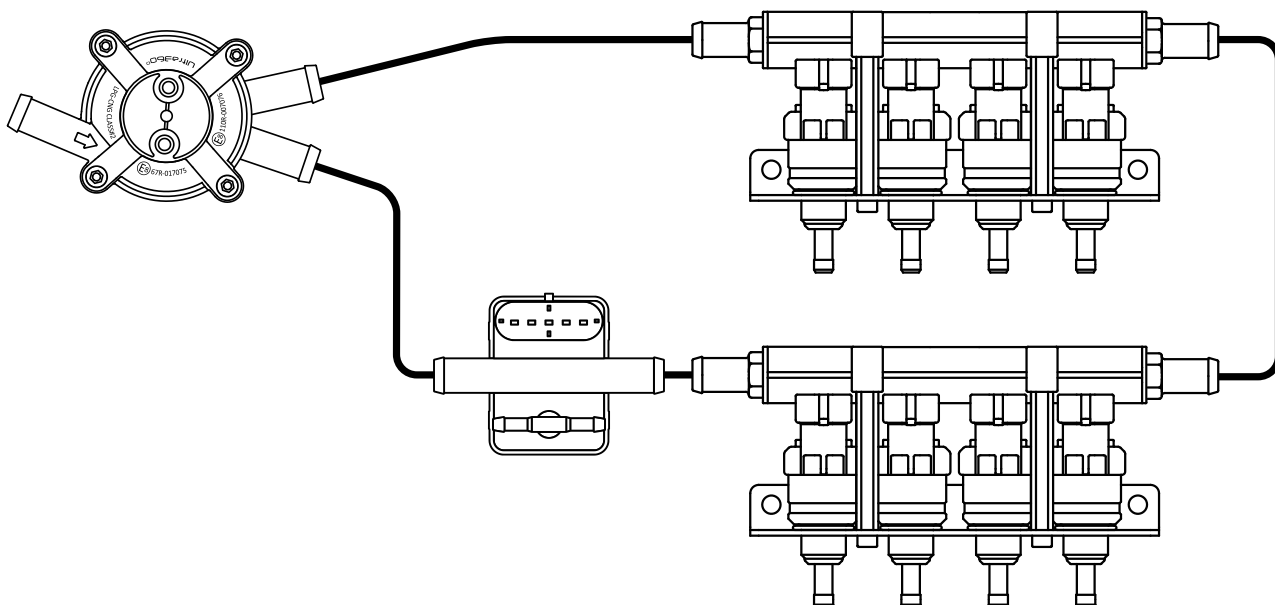

Article	Code
Filter GF1622	C052-16-22-01-00
2x injection rail BR124P	C032-04-04-00-00
2 x Tubo Barracuda d12 M14x1	C032-00-00-02-99

3.2. Single injectors with connectors + gas distributor "4":

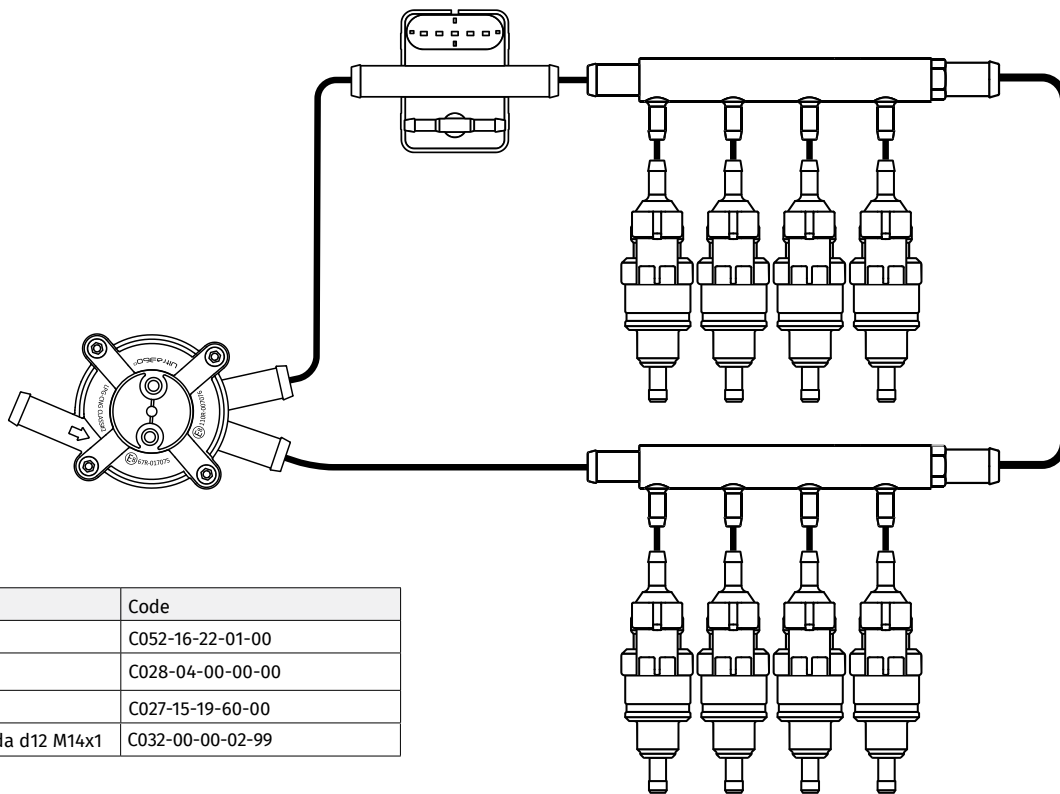

Article	Code
Filter GF1622	C052-16-22-01-00
2x gas distributor	C028-04-00-00-00
injector	C027-15-19-60-00
8 x Tubo Barracuda d12 M14x1	C032-00-00-02-99

3.3. Single injectors + t-type adapters:

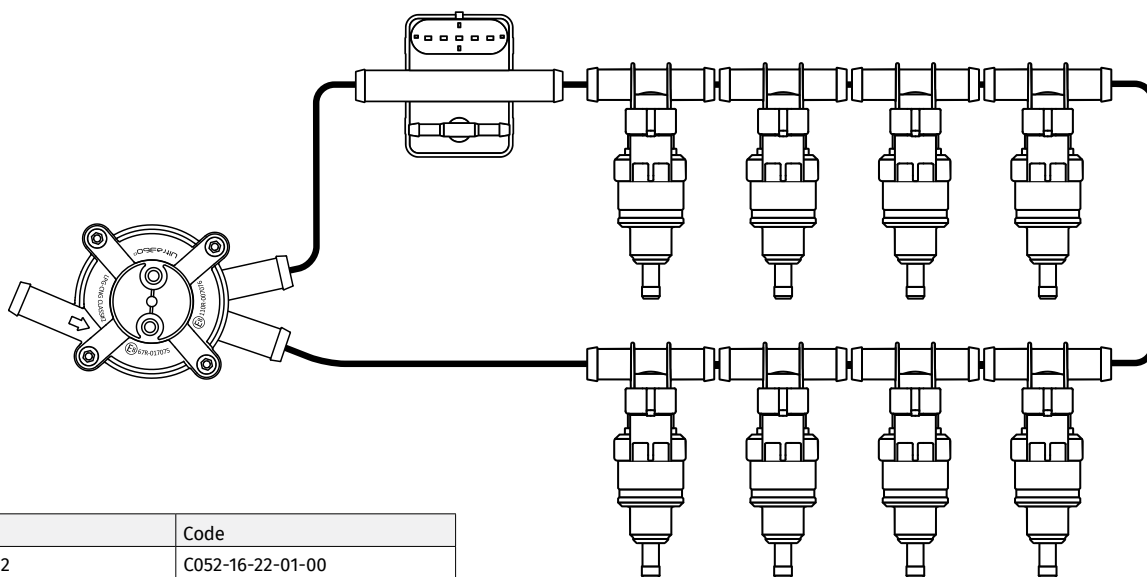

Article	Code
Filter GF1622	C052-16-22-01-00
8x injector	C027-15-19-60-00
8x T-type adapter BD221P	C056-00-00-01-99

Recommended composition and installation of injectors with 4,6 and 8 cylinder engines depending on the power and engine type.

3.4. When connecting two reducers:

Article	Code
filter GF1212 or GF1612 depending on the reducer's outlet diameter (12 or 16 mm)	C052-10-10-00-00 or C052-16-22-01-00
injector	C027-15-19-60-00
T-type adapter BD221P	C056-00-00-01-99

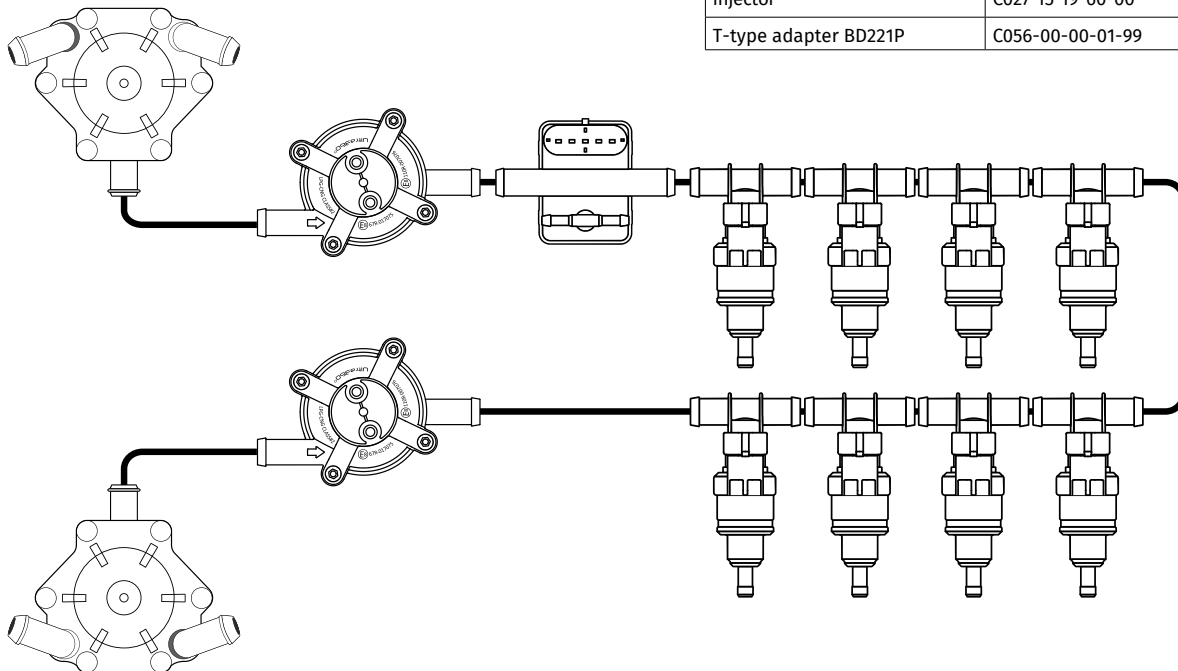

3.5. Or:

Article	Code
Filter 4x12	FIL00066
8x injector	C027-15-19-60-00
8x T-type adapter BD221P	C056-00-00-01-99

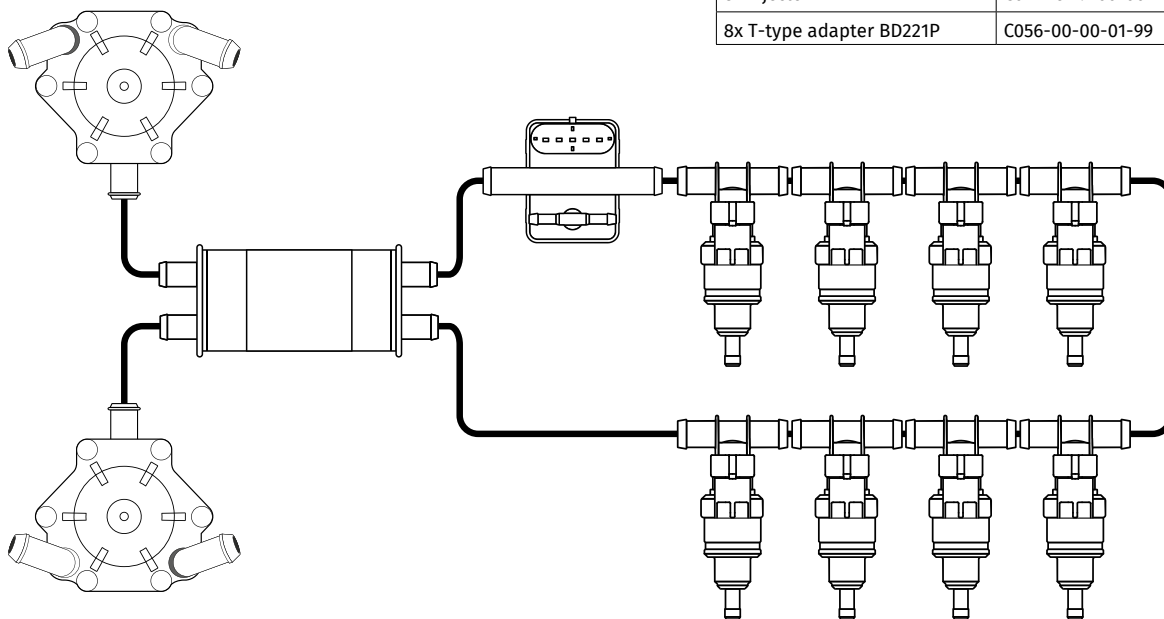

Recommended composition and installation of injectors with 4,6 and 8 cylinder engines depending on the power and engine type.



To connect the ends of injector rails we use:

Article	Code
Barracuda rail connector d12 M14x1	C032-00-00-02-99



to connect the ends of gas distributors we use :

Article	Code
gas distributor connector d12 M12x1	C010-01-06-00-01